



## The oriented chromatic number of some grids

Halina Bielak\*

*Institute of Mathematics, M. Curie-Skłodowska University,  
Pl. M. Curie-Skłodowskiej 1, 20-031 Lublin, Poland*

### Abstract

We define some infinite subfamily of hexagonal grids with the oriented chromatic number 5. We present an algorithm for oriented colouring of some hexagonal planar oriented grids. The algorithm uses BFS spanning tree of a subgraph of the dual graph of the grid and a homomorphism to some tournament of order 6. In general the difference between the number of colours given by the algorithm and the oriented chromatic number is at most 1.

### 1. Introduction

We consider simple graphs and oriented digraphs. The simple graph  $G = (V, E)$  is the pair of sets, where the second set consists of some two element subsets (edges) of the first set. The digraph  $D = (V, A)$  is the pair of sets, where the second set consists of some pairs of elements (arcs) from the first set. We say that  $D$  is the oriented digraph if  $A$  does not contain opposite arcs (if  $A$  is antisymmetric relation on  $V$ ). The oriented colouring and its relation to another type of colourings of graphs and digraphs is studied recently. Most of the results are published in [1-14]. Some important application of oriented colouring to study antisymmetric flows is presented in [10,11]. In this paper we study the oriented chromatic number for some planar and non planar grids. In particular, we give infinite subfamily of hexagonal grids with the oriented chromatic number 5. We extend a result of Fertin [4] to some family of square grids. Moreover, we present an algorithm for oriented colouring of hexagonal planar grids with some constrains. The basic notions and notations are defined below. The notions not defined here one can find in [3].

*Homomorphism of the oriented digraph  $D_1 = (V_1, A_1)$  to the oriented digraph  $D_2 = (V_2, A_2)$  is defined as mapping  $\varphi$  from the vertex set of  $D_1$  to the vertex set of  $D_2$  satisfying the condition:*

*if  $(x, y)$  is an arc in  $D_1$ , then  $(\varphi(x), \varphi(y))$  is an arc in  $D_2$ .*

---

\*E-mailaddress: [hbiel@golem.umcs.lublin.pl](mailto:hbiel@golem.umcs.lublin.pl)

Two oriented digraphs  $D_1 = (V_1, A_1)$  and  $D_2 = (V_2, A_2)$  are *isomorphic* if there exists a bijective mapping  $\varphi$  from  $V_1$  to  $V_2$  satisfying the following condition:

$$\forall_{a,b \in V_1} ((a,b) \in A_1) \Leftrightarrow ((\varphi(a), \varphi(b)) \in A_2).$$

The *proper vertex colouring* of the graph  $G = (V, E)$  is a mapping  $c : V \rightarrow N$  such that the adjacent vertices  $u, v \in V$  have different colours, i.e.,  $\{u, v\} \in E \Rightarrow c(u) \neq c(v)$ .

Given the positive integer  $k$ , if there exists a proper vertex colouring of  $G$  with  $k$  colours, then we say that  $G$  is *k-colourable*. The minimum number  $k$ , such that the graph  $G$  is *k-colourable* is called the *chromatic number* of  $G$  and denoted by  $\chi(G)$ .

The *oriented colouring* is a colouring  $c$  of the vertex set of the oriented digraph  $\vec{G} = (V(\vec{G}), A(\vec{G}))$  satisfying the following conditions:

- if  $(u, v) \in A(\vec{G})$ , then  $c(u) \neq c(v)$ ,
- for any pair of arcs  $(u, v), (x, y) \in A(\vec{G})$ , if  $c(u) = c(y)$  then  $c(x) \neq c(v)$ .

The *oriented chromatic number*  $\vec{\chi}(\vec{G})$  of the oriented digraph  $\vec{G}$  is the minimum number of colours over all oriented colourings of  $\vec{G}$ .

Let  $O_G$  be the family of all possible orientations of the simple graph  $G$ . The *oriented chromatic number*  $\vec{\chi}(G)$  of the simple graph  $G$  is defined as the maximum oriented chromatic number over all possible orientations of  $G$ , i.e.,

$$\vec{\chi}(G) = \max \left\{ \vec{\chi}(\vec{G}) \mid \vec{G} \in O_G \right\}$$

Evidently, the oriented digraph  $D_1$  can be coloured by  $k$  colours if and only if there exists a homomorphism  $\varphi$  from  $D_1$  to an oriented digraph  $D_2$  of order  $k$ . So the problem of finding the oriented chromatic number of an oriented digraph  $D_1 = (V_1, A_1)$  is the problem of finding an oriented digraph  $D_2 = (V_2, A_2)$  of minimum order, such that there exists a homomorphism  $\varphi: D_1 \rightarrow D_2$ . We say, that  $D_1$  is *coloured by a homomorphism to  $D_2$* . We say that  $D_1$  is  *$D_2$ -colourable*, if and only if there exists a homomorphism from  $D_1$  to  $D_2$ . The vertices of  $D_2$  are called the *colours*. The following digraphs are very useful for studying the oriented colourings of graphs. Two of them are presented in Figure 1.

- $T_5$  is the digraph with the vertex set  $V = \{0, 1, \dots, 4\}$  and the arc set

$$A = \left\{ (x, (x+k) \bmod 5) \mid x \in V, k=1,2 \right\};$$

- $T_6$  is the digraph with the vertex set  $V = \{0, 1, \dots, 5\}$  and the arc set

$$A = \left\{ (x, (x+1) \bmod 6) : x \in V \right\} \cup \left\{ (x, (x+k) \bmod 6) : x \in V \wedge 2 \mid x, k=2,3 \right\} \cup$$

$$\left\{ (x, (x+4) \bmod 6) \mid x \in V \wedge \neg 2 \mid x \right\};$$

- $T_7$  is the digraph with the vertex set  $V = \{0, 1, \dots, 6\}$  and the arc set  $A = \{(x, (x+k) \bmod 7) \mid x \in V, k = 1, 2, 4\}$ ;
- $T_{11}$  is the digraph with the vertex set  $V = \{0, 1, \dots, 10\}$  and the arc set  $A = \{(x, (x+k) \bmod 11) \mid x \in V, k = 1, 3, 4, 5, 9\}$ .

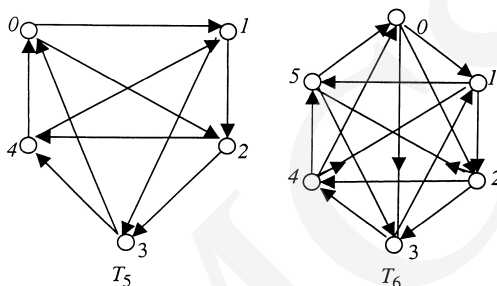

Fig. 1. The orientation  $T_5$  of the complete graph of order 5 and the orientation  $T_6$  of the complete graph of order 6

The average degree  $ad(H)$  of the graph  $H$  is defined as follows

$$ad(H) = \frac{2|E(H)|}{|V(H)|}.$$

The maximum average degree  $mad(G)$  of the graph  $G$  is defined as maximum of average degrees  $ad(H)$  over all subgraphs  $H$  of the graph  $G$ , i.e.  $mad(H) = \max\{ad(H) : H \subseteq G\}$ .

The girth  $g(G)$  of the graph  $G$  is the order of the shortest cycle in  $G$ .

The following theorem presents some relation between the oriented chromatic number and the maximum average degree.

**Theorem 1.** (Borodin [2]).

1. For any graph  $G$  with  $mad(G) < \frac{7}{3}$ ,  $\bar{\chi}(G) \leq 5$ .
2. For any graph  $G$  with  $mad(G) < \frac{11}{4}$  and  $g(G) \geq 5$ ,  $\bar{\chi}(G) \leq 7$ .
3. For any graph  $G$  with  $mad(G) < 3$ ,  $\bar{\chi}(G) \leq 11$ .
4. For any graph  $G$  with  $mad(G) < \frac{10}{3}$ ,  $\bar{\chi}(G) \leq 19$ .

## 2. The oriented colourings of square grids

In this section we give a short survey of known results for planar graphs, in particular for planar square grids. Moreover, we extend some of them for other square grids. The following theorems show some upper bounds for the oriented

chromatic number of planar graphs with respect to the maximum degree and the girth of the graph.

**Theorem 2.** (Raspaud and Sopena [9]). Any oriented planar digraph has an oriented colouring with at most  $5 \cdot 2^4$  colours.

**Theorem 3.** (Kostochka [6]). If  $G = (V, E)$  is a graph of maximum degree  $k$ , then  $\bar{\chi}(G) \leq 2 \cdot k^2 2^k$ .

**Theorem 4.** (Borodin [2]). Let  $G$  be a simple planar graph with the girth  $g(G)$ .

- 1) If  $g(G) > 13$ , then  $\bar{\chi}(G) \leq 5$ .
- 2) If  $g(G) > 7$ , then  $\bar{\chi}(G) \leq 7$ .
- 3) If  $g(G) > 5$ , then  $\bar{\chi}(G) \leq 11$ .
- 4) If  $g(G) > 4$ , then  $\bar{\chi}(G) \leq 19$ .

The special subfamily of planar square grids are two-dimensional grids. The two-dimensional grid  $G(m, n)$  is the cartesian product of two paths of orders  $m$  and  $n$ , respectively, i.e.,  $G(m, n) = P_m \times P_n$  (see Figure 2 for some examples).

The family of all  $G(m, n)$ , where  $m, n$  are positive integers we denote by  $G_2$ . The oriented chromatic number for a family  $F$  of graphs is defined as follows:

$$\bar{\chi}(F) = \max \{ \bar{\chi}(G) \mid G \in F \}.$$

Some big two-dimensional grids can be optimally coloured by digraphs  $T_{11}$ ,  $T_7$  or  $T_6$ . The upper bound for the oriented chromatic number of  $G(m, n)$  in general case is given by the respective homomorphism to  $T_{11}$ . The nice property of  $T_{11}$  cited below is very useful to study the upper bound.

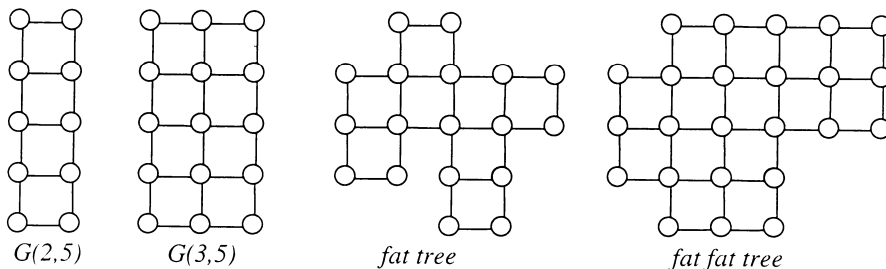

Fig. 2. Two two-dimensional grids  $G(2,5)$  and  $G(3,5)$ . The examples of fat tree and fat fat tree

**Proposition 5.** (Borodin, et al. [2]). For any two vertices  $u, v$  of  $T_{11}$  there are at least two different paths of length 2 with an arbitrary orientation, joining the vertices  $u$  and  $v$ .

**Theorem 6.** (Fertin, et al. [4]). Let  $m, n$  be integers and let  $G_2$  be the family of two-dimensional grids  $G(m, n)$ , then  $8 \leq \bar{\chi}(G_2) \leq 11$ .

The colouring of  $G(2,n)$  by  $T_6$  is discovered by Fertin, Raspaud and Roychowdhury [4]. For this narrow two-dimensional grid they obtained the result presented below.

**Proposition 7.** (Fertin, et al. [4]). For any  $n > 3$ ,  $\bar{\chi}(G(2,n)) = 6$  and  $\bar{\chi}(G(2,2)) = 4$ ,  $\bar{\chi}(G(2,3)) = 5$ .

The following property of  $T_6$  is very useful to study narrow two-dimensional grids. This property is very interesting for the oriented colouring of other grids studied in this paper, as well.

**Proposition 8.** For any two vertices  $u$  and  $v$  of  $T_6$  there exists a walk  $P=(u,u',v',v)$  of length 3 with an arbitrary orientation of three arcs.

**Proof.** Without loss of generality we can consider two cases for  $u$ , namely  $u = 0$  and  $u = 1$ . □

Recently, Szepietowski and Targan [14] discovered the optimal oriented colouring of  $G(3, n)$  and  $G(4,n)$  by  $T_7$ . The digraph  $T_7$  has some number of automorphisms, for example:  $h(x) = (x + n) \bmod 7$ , for any integer  $n$ ;  $h(x) = (2x) \bmod 7$ ,  $h(x) = (4x) \bmod 7$ ,  $h(x) = (7-x) \bmod 7$ , where  $x$  is a vertex of  $T_7$ . The last automorphism reverses any arc of  $T_7$ , i.e., it maps any arc  $(u,v)$  into the arc  $(v,u)$ , where  $u, v$  are any different vertices of  $T_7$ .

**Proposition 9.** (Szepietowski and Targan [14]). There exists an automorphism of  $T_7$  mapping any arc  $(u, v)$  of  $T_7$  into the arc  $(0, 1)$ .

**Proposition 10.** (Szepietowski and Targan [14]). Let  $G$  be an oriented two-dimensional grid and let  $(u,v)$  be an arc of  $G$ . Then the following theorems are equivalent:

- 1) there exists a homomorphism  $h$  from  $G$  to  $T_7$ ,
- 2) there exists a homomorphism  $h$  from  $G$  to  $T_7$  so that  $h(u) = 0$  and  $h(v) = 1$ .

**Proposition 11.** (Fertin, et al. [4]). For any orientation of the graph  $E_3$  and any colouring of the vertices  $x, y, z$  with colours from the set  $\{0,1,2,3,4,5,6\}$  there exists a colouring of the vertices  $x', y', z'$  preserving the homomorphism to  $T_7$ , where the graph  $E_3$  is presented in Figure 3.

**Proposition 12.** (Szepietowski and Targan [14]). For  $n = 3, 4, 5, 6, \dots$ ,  $\bar{\chi}(G(3,n)) = 6$  and for any  $n > 6$ ,  $\bar{\chi}(G(3,n)) = 7$ . For any  $G(4,n)$  there exist a homomorphism to  $T_7$ .

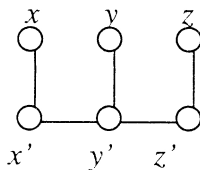

Fig. 3. The graph  $E_3$

The above facts are very useful to study subgraphs of two-dimensional grids, called fat trees and fat fat trees and defined by Fertin, Raspaud and Roychowdhury in [4]. They glue grids  $G(2,n)$  into fat trees, and glue grids  $G(3,n)$  into fat fat trees with the restriction to the subgraphs of  $G(n,m)$  (see Figure 2 for the examples). The fat trees can be coloured in the same way as  $G(2,n)$ . The fat fat trees can be coloured in the same way as  $G(3,n)$ .

The oriented chromatic number of the family of fat trees and fat fat trees are cited below.

**Proposition 13.** (Fertin, et al. [4]). *Let  $F_T$  be the family of fat trees. Then  $\bar{\chi}(F_T) = 6$ . Let  $FF_T$  be the family of fat fat trees. Then  $\bar{\chi}(FF_T) = 7$ .*

We extend the above result to other square grids. Namely, let  $S$  be the family of graphs constructed from the cycle  $C_4 = G(2,2)$  by successive edge gluing of a new copy of  $C_4$ . The family  $S$  contains the family of fat trees. Evidently each graph of the family is planar. Let  $FS$  be the family of graphs defined as follows. The smallest graph of the family  $FS$  is  $G(2,3)$ . For  $n > 5$ , the graph  $H$  of order  $n+3$  belongs to  $FS$  if it can be constructed from a graph  $G$  of order  $n$  belonging to  $FS$  by gluing the vertices  $x,y,z$  of a new copy of  $E_3$  to the consecutive vertices of a path  $P_3$  in  $G$ . No other graph belongs to  $FS$ . The family  $FS$  contains all fat fat trees and some non planar square grids. The examples of graphs in the families are presented in Figures 2 and 4. The graphs presented in Figure 4 are neither fat tree nor fat fat tree.

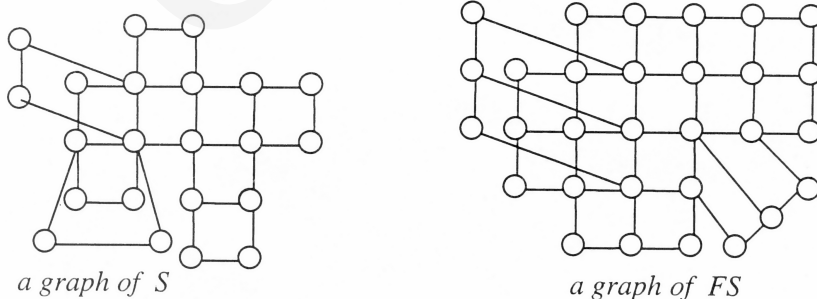

Fig. 4. The square grids of  $S$  and  $FS$

**Proposition 14.** Let  $S$  and  $FS$  be the families defined above. Then  $\bar{\chi}(S) = 6$  and  $\bar{\chi}(FS) = 7$ .

**Proof.** Immediately by Propositions 8 and 11. The graphs of the family  $S$  we colour by  $T_6$ , and the graphs of the family  $FS$  we colour by  $T_7$ . □

### 3. Hexagonal grids

In this section we give some new results for oriented colouring of planar hexagonal grids. In particular we study the grids for which there exists a planar imbedding with at most one region with the boundary greater than 6 and such that any two hexagons have at most one common edge. The linear hexagonal grid  $H_n = H_{1,n}$  is defined recursively as follows.  $H_{1,1} = C_6$ . For  $n > 1$ ,  $H_{1,n}$  is constructed from  $H_{1,n-1}$  by edge gluing of the new  $C_6$  to the last right edge of  $H_{1,n-1}$ . If starting from  $C_6$  we successively glue the new  $C_6$  to an arbitrary edge of the hexagonal grid with  $n-1$  hexagons then we obtain hexagonal tree with  $n$  hexagons. The 2-linear hexagonal grid  $H_{2,n}$  is a particular case of fat hexagonal tree and is defined recursively as follows.  $H_{2,1} = H_{1,2}$ . For  $n > 1$ ,  $H_{2,n}$  is constructed from  $H_{2,n-1}$  by gluing of the new  $H_{1,2}$  to the last right path  $P_4$  of  $H_{2,n-1}$ . The examples of the linear hexagonal grid and the 2-linear hexagonal grid are presented in Figure 5. The last right edge is denoted by  $x, y$  in Figure 5(a), and the last right path  $P_4$  is denoted by  $u, w, x, y$  in Figure 5(b).

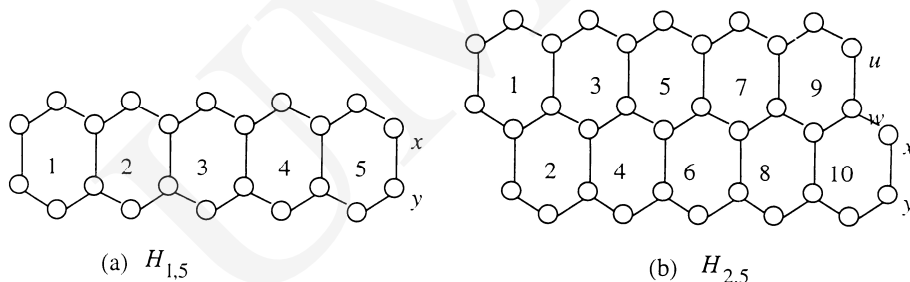

Fig. 5. The planar imbedding of  $H_{1,5}$  and  $H_{2,5}$ . The numbers inside the hexagons are their labels. The optimal oriented colouring is constructed by extending the partial colouring by homomorphism to  $T_5$  for successive hexagons according to increasing labels

First we prove the following lemma.

**Lemma 15.** *Let  $t$  be an integer,  $4 < t$ . For any orientation of the path  $P_t = (x_0, x_1, x_2, x_3, \dots, x_{t-1})$  joining the vertices  $x_0$  and  $x_{t-1}$ , and for any colouring of  $x_0$  and  $x_{t-1}$  by colours of the set  $\{0, 1, 2, 3, 4\}$  there exists a colouring of  $x_1, x_2, x_3, \dots, x_{t-2}$  preserving the homomorphism to  $T_5$ .*

**Proof.** (By induction on  $t$ ). First we show that the theorem is true for  $t = 5$ . By symmetry of  $T_5$  we can set the colour 0 for  $x_0$ , i.e.  $c(x_0) = 0$ . Moreover, by the symmetry, it is sufficient to consider the orientations of  $P_5$  presented in Figure 6. The respective colouring of the inside vertices of  $P_5$  by  $T_5$  are listed in the table. Suppose that the theorem is true for each positive integer  $4 < n < t$ . By taking the vertex  $x_{t-2}$  with the colour  $c(x_{t-2}) = (c(x_{t-1}) + 1) \bmod 5$  and  $c(x_{t-2}) = (c(x_{t-2}) - 1) \bmod 5$ , we extend the result from  $P_{t-1}$  to  $P_t$ .  $\square$

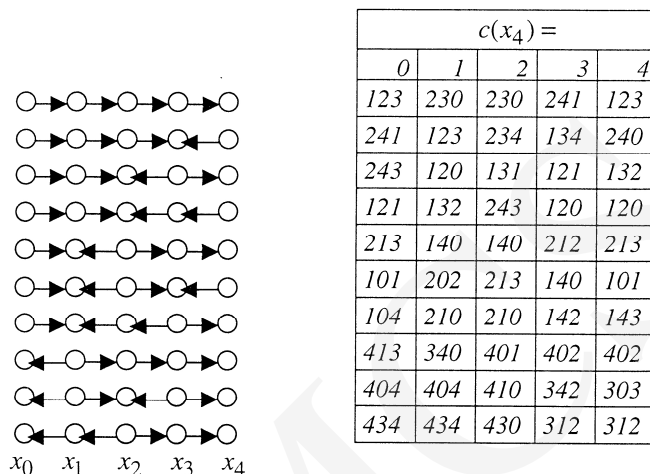

Fig. 6. The orientations of the path  $P_5$  and the oriented colourings by  $T_5$ .  
We assume that  $c(x_0) = 0$

We prove the following result.

**Theorem 16.** *Let  $n$  be a positive integer. For any  $n > 3$  we have  $\bar{\chi}(H_n) = 5$ .*

**Proof.** Let  $O_4$  be the family of all orientations of the simple graph  $K_4$ . We show that the Figure 7 presents the oriented hexagonal grid  $\bar{H}_4^0$  without any homomorphism to any digraph of the family  $O_4$ . Suppose that  $\bar{\chi}(\bar{H}_4^0) \leq 4$ . Without loss of the generality we set  $c(q) = 0$ ,  $c(h) = 1$ ,  $c(p) = 2$ . Then  $c(r) \in \{0, 3\}$ . Suppose that  $c(r) = 0$ . Then  $c(s) = 3$ ,  $c(f) = c(k) = 2$  and  $c(x) \in \{0, 1, 3\}$ . Note that  $c(x) \neq 0$ , else  $c(y) > 3$  and we get a contradiction. If  $c(x) = 3$  then  $c(y) = 0$  and  $c(g) > 3$ , a contradiction. If  $c(x) = 1$  then  $c(a) > 3$ , a contradiction. Thus  $c(r) = 3$ . Hence  $c(i) = 1$ ,  $c(s) = 0$ ,  $c(k) = 2$  and  $c(j) = 1$ . Thus  $c(w) > 3$ , a contradiction.

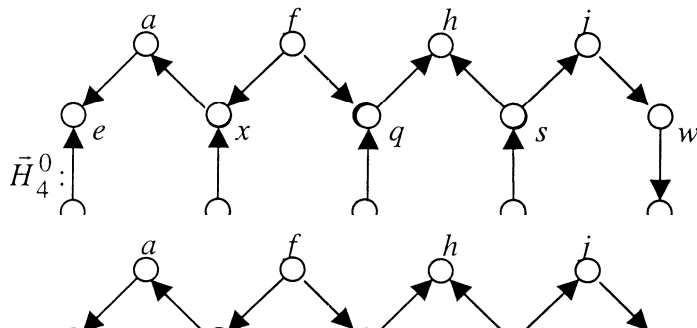

Fig. 7. The orientation  $\bar{H}_4^0$  of the linear hexagonal grid  $H_{1,4}$

So  $\bar{\chi}(H_n) > 4$ , for  $n > 3$ . By Lemma 15, note that for any orientation of  $H_1 = H_{1,1} = C_6$  there exists a homomorphism to  $T_5$ . So  $\bar{\chi}(H_1) \leq 5$ . Thus, by induction on the number of hexagons and by Lemma 15 for  $t = 6$ , we get  $\bar{\chi}(H_n) \leq 5$  for each positive integer  $n$ . The proof is done.  $\square$

The hexagonal tree is obtained by edge gluing of linear hexagonal grids. The fat hexagonal tree is obtained by a  $P_4$ -gluing of 2-linear hexagonal grids. The examples are presented in Figure 8. More precisely, we construct the family of fat hexagonal trees recursively. We assume  $H_{1,2}$  as the smallest fat hexagonal tree. The fat hexagonal tree  $H$  of order  $n$ , where  $n > 6$  and  $6|n$ , we obtain from a fat hexagonal tree  $F$  of order  $n-6$  by gluing the graph  $B_3$  presented in Figure 9 to a path  $(u, w, x, y)$  of the graph  $F$ . The family contains non planar hexagonal grids. The oriented chromatic number for these families is presented below.

**Theorem 17.** Let  $HT$  be the family of all hexagonal trees. Then  $\bar{\chi}(HT) = 5$ .

**Proof.** Immediately by Lemma 15 with  $t = 6$ .  $\square$

**Theorem 18.** Let  $FHT$  be the family of all fat hexagonal trees. Then  $\bar{\chi}(FHT) = 5$ .

**Proof.** Let  $H$  be a graph of the family  $FHT$  and  $\bar{H}$  be any orientation of  $H$ . We apply Lemma 15 with  $t = 6$  and  $t = 5$ . First we colour the smallest oriented grid of the family by  $T_5$ . Then we extend the oriented colouring to the oriented colouring of  $\bar{H}$  by the colouring of the sequence of respective orientations of subgraphs isomorphic to  $B_3$  taking them accordingly to the recursive construction of  $H$ . First, we colour by  $T_5$  the inside vertices of the path  $(u, a, b, c, x)$  and then we colour the inside vertices of the path  $(c, d, e, f, y)$ .  $\square$

The example for the respective order for the extending of the oriented colouring is presented in Figure 8.

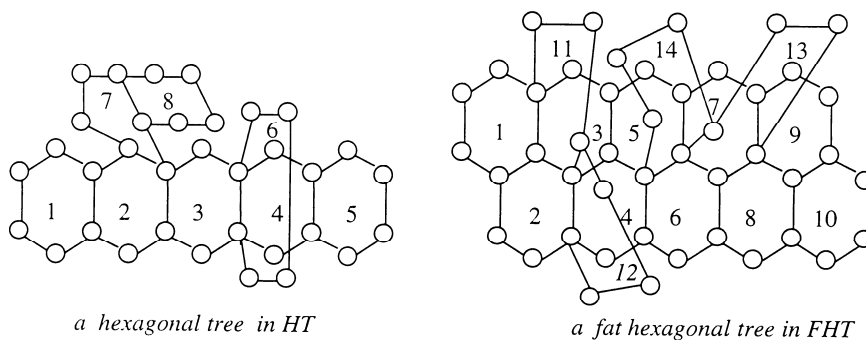

Fig. 8. The example of hexagonal tree and fat hexagonal tree. The numbers inside the hexagons are their labels. The optimal oriented colouring is constructed by extending the partial colouring by homomorphism to  $T_5$  for successive hexagons according to the increasing labels

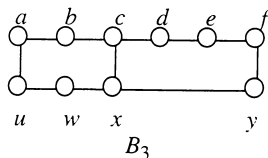

Fig. 9. The graph  $B_3$ . The vertices  $u, w, x$  and  $y$  are properly precoloured, i.e., the path  $P_4 = (u, w, x, y)$  is contained in  $F$ . The vertices  $a, b, c, d, e$  and  $f$  are coloured by  $T_5$  as follows: first we take the path  $(u, a, b, c, x)$  to extend the colouring to the vertices  $a, b, c$  and then we take the path  $(c, d, e, f, y)$  to extend the colouring to the vertices  $d, e, f$

To study other hexagonal grids we need the following lemma.

**Lemma 19.** *Let  $t$  be an integer,  $3 < t$ . For any orientation of the path  $P_t = (x_0, x_1, x_2, x_3, \dots, x_{t-1})$  joining the vertices  $x_0$  and  $x_{t-1}$ , and for any colouring of  $x_0$  and  $x_{t-1}$  by colours of the set  $\{0, 1, 2, 3, 4, 5\}$  there exists a colouring of  $x_1, x_2, x_3, \dots, x_{t-2}$  preserving the homomorphism to  $T_6$ .*

**Proof.** (By induction on  $t$ ). Immediately by Proposition 8 we get the result for  $t = 4$ . Suppose that the theorem is true for each positive integer  $3 < n < t$ . By taking the vertex  $x_{t-2}$  with the colour  $c(x_{t-2}) = (c(x_{t-1}) + 1) \bmod 6$  and  $c(x_{t-2}) = (c(x_{t-1}) - 1) \bmod 6$  we extend the result from  $P_{t-1}$  to  $P_t$ . □

Now we prove the following result.

**Theorem 20.** *Let  $H$  be a 2-connected planar hexagonal grid of maximum degree at most 3 with  $n$ , ( $n > 3$ ) hexagons such that any two hexagons have at most one common edge and there exists planar imbedding of  $H$  with at most one non hexagonal region. Then  $5 \leq \tilde{\chi}(H) \leq 6$ .*

**Proof.** Let  $H$  be a hexagonal planar grid with  $n$  hexagons satisfying the assumption of the theorem. By Theorem 16 we have  $5 \leq \tilde{\chi}(H)$ . The upper bound we get by the oriented colouring of  $H$  by  $T_6$  according to the algorithm **OHPC** presented below. The algorithm is based on Lemma 19. Let  $R$  be the graph with the vertices representing the hexagons of  $H$ . Two vertices of  $R$  are adjacent if and only if the respective hexagons have a common edge (unique one) in the grid  $H$ . Let  $\vec{H}$  be any orientation of  $H$ .

The algorithm OHPC (oriented colouring of oriented hexagonal planar grid by  $T_6$ ):

Imbed the grid  $H$  into the plane according to the assumption of the theorem.

Let  $T$  be a spanning BFS tree for  $R$ . {By BFS we mean the breadth first search.}

Let  $x_1, x_2, x_3, x_4, \dots, x_n$  be the order of vertices of  $T$  obtained by BFS algorithm.

**FOR**  $i=1(1)n$  **DO**

Take the noncoloured vertices of  $\bar{H}$  from the boundary of the hexagon represented by  $x_i$ . The vertices create either an oriented path of order  $q$ , where  $1 < q < 5$  (i.e., the vertices are the inside vertices of a path  $P_{q+2}$ ), or an oriented cycle of order 6 (the last case is for the root of  $T$ ). Denote the oriented subgraph by  $S$ .

For each vertex  $v$  of  $S$  find the respective homomorphism preserving colouring by  $T_6$ .

Note that the partial oriented colouring can be extended by Lemma 19. □

The example of the grid satisfying the conditions of Theorem 20 is presented in Figure 10.

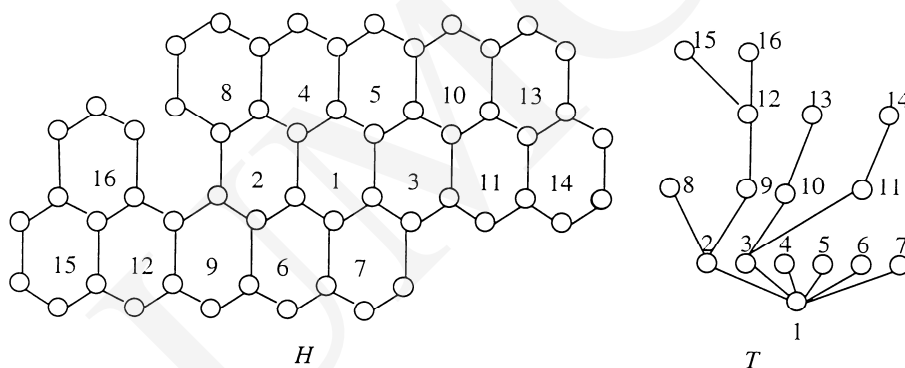

Fig. 10. The grid  $H$  with the respective BFS spanning tree  $T$  constructed in the increasing order of labels inside of hexagons

The algorithm OHPC presented in the proof of Theorem 20 can be applied to any oriented colouring of planar hexagonal grid  $H$  with the connectivity at most 1 such that each block of the grid satisfies the assumption of the theorem, as well. The block is the maximal 2-connected component of the graph. In the case we can use a spanning BFS forest  $F$  for  $R$  instead of a spanning BFS tree  $T$  and we colour the oriented grid according to some special order of trees of the forest. Namely, first we create a block representation tree  $B$  of the grid. The block tree has the blocks of  $H$  as vertices. Two vertices of  $B$  are adjacent iff the respective blocks have a common vertex. Then we number the vertices of  $B$  by BFS. We take the increasing order of the vertices of  $B$  as the order of blocks of  $H$  and we consider the blocks successively according to this order. For the first block we can create BFS tree with the root in the arbitrary hexagon. For each other block we create the respective BFS tree with the root representing the unique hexagon with precoloured vertex. The order of BFS trees is induced by the order of vertices in  $B$ . We apply the algorithm OHPC for each consecutive block.

If two hexagons of a planar grid  $H$  have at least two common edges or there exists no planar imbedding of  $H$  with at most one not hexagonal region, then the algorithm OHPC cannot produce any oriented colouring by  $T_6$ . The example of critical grid  $F$  is presented in Figure 11. Note that if after 9th step the algorithm gives  $c(u) = c(y)$ , then the colouring cannot be extended to the vertex  $x$ . It follows by too small length of the path  $P = (u, x, y)$ . A critical orientation of the grid and the colouring by  $T_6$  after 9th step of the algorithm is presented in Figure 12.

Similarly, the grid obtained from  $F$  by deleting of the edges  $\{a, c\}$  and  $\{c, b\}$  is critical for the OHPC algorithm. In fact, there exists an infinite family of the critical graphs.

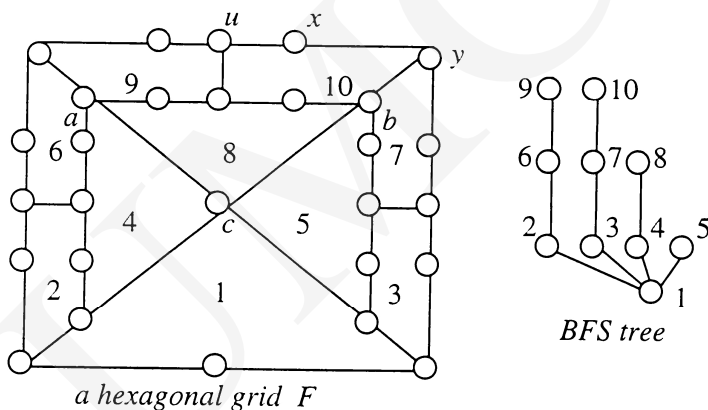

Fig. 11. The planar grid  $F$  without colouring by  $T_6$  according to the algorithm OHPC. The respective BFS spanning tree  $T$  is constructed in the increasing order of labels inside hexagons

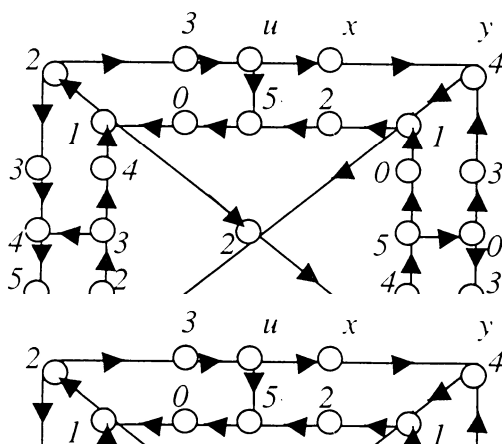

Fig. 12. A critical orientation  $\vec{F}$  of the grid  $F$  and the colouring by  $T_6$  after 9th step of the algorithm. If  $c(u) = 4$  then the orientation of the path  $P = (u, x, y)$  leads to a non proper colouring of  $\vec{F}$

### Conclusions

Note that  $mad(H_{1,n}) > 7/3$  and  $mad(H_{2,n}) > 11/4$ . So we cannot use Theorem 1 for the proof of Theorems 16-18. There is a question, what is the smallest grid satisfying the conditions of Theorem 20 with oriented chromatic number 6, (if such exists)? We conclude with the following open question for two-dimensional grids. What are the minimum positive integers  $m$  and  $n$  such that  $\bar{\chi}(G(m,n)) = k$  for any  $k$  ( $5 < k < 12$ )?

### References

- [1] Borodin O.V., *On acyclic coloring of planar graphs*, Discr. Math., 25 (1979) 211.
- [2] Borodin O.V., Kostochka A.V., Nešetřil J., Raspaud A., Sopena E., *On the maximum average degree and the oriented chromatic number of a graph*, Discr. Math., 206 (1999) 77.
- [3] Chartrand G., Lesniak L., *Graphs Digraphs*, Chapman & Hall, Third Edition, (1996)
- [4] Fertin G., Raspaud A., Roychowdhury A., *On the oriented chromatic number of grids*, Information Processing Letters, 85 (2003) 261.
- [5] Klostermeyer W.F., MacGillivray G., *Homomorphisms and oriented colorings of equivalence classes of oriented graphs*, Discr. Math., 274 (2004) 161.
- [6] Kostochka A.V., Sopena E., Zhu X., *Acyclic and oriented chromatic numbers of graphs*, J. Graph Theory, 24 (1997) 331.
- [7] Nešetřil J., Raspaud A., *Colored homomorphisms of colored mixed graphs*, J. Combin. Theory Ser., B 80 (2000) 147.
- [8] Ochem P., *Oriented colorings of triangle-free planar graphs*, Information Processing Letters, 92 (2004) 71.
- [9] Raspaud A., Sopena E., *Good and semi-strong colorings of oriented planar graphs*, Information Processing Letters, 51(1994) 171.
- [10] Samal R., *Antisymmetric flows and strong oriented colorings of planar graphs*, Discr. Math., 273 (2003) 203.
- [11] Samal R., *Antiflows, oriented and strong oriented colorings of graphs*, Arch. Math., 40 (2004) 335.
- [12] Sopena E., *Oriented graph coloring*, Discr. Math., 229 (2001) 359.
- [13] Sopena E., *There exist oriented planar graphs with oriented chromatic number at least sixteen*, Information Processing Letters, 81 (2002) 309.
- [14] Szepietowski A., Targan M., *A note on the oriented chromatic number of grids*, Information Processing Letters, 92 (2004) 65.