



Multi-channel recorder for I-V curves

Jerzy Kotliński*

*Institute of Computer Science, Maria Curie-Skłodowska University,
Pl. M. Curie-Skłodowskiej 1, 20-031 Lublin, Poland*

Abstract

The operation of nine – channel microprocessor controlled recorder to be used for concurrent recording of current – voltage characteristics in two or three electrode configurations has been described in the present study. The prototype version of the recorder as been designed for measurements associated with determination of oxygen stream density in the course of soil oxygen micro-diffusion. The common setting of measurement parameters in the scope of three measuring channels is possible by means of recorder operation program enabling the execution of the measurement in three measuring groups which are independent of each other. The measurements in cycles lasting several days with automatic measurement results recording are possible by means of the recorder.

1. Introduction – voltammetric measurements

The electro-analytical methods are characterized as one of instrumental methods group being used for determination of small and extremely small contents of substances in the medium being tested. The polarography, voltametry or amperometric titration are the methods based upon the measurement of current between two polarized electrodes immersed in electrolyte [1]. The behaviour of a closed electric circuit with flowing electric current is encompassed with testing in each of *a/m* methods. The measurement consists in drawing of current – voltage characteristics (I-V) and its analysis for the object being tested. The shape of voltammetric curves (current – voltage characteristics) representing the value of current versus the applied voltage reflects the qualitative and quantitative composition of the solution being analysed (Figure 1b).

The instrument described in the present study has been built in order to enable the determination of oxygen stream density in the course of soil oxygen micro-diffusion [2,3]. Each electrode after its immersion in the electrolyte (soil) assumes a relative potential E_1 , E_2 and E_3 which is the characteristic value for

*E-mail address: jotkot@tytan.umcs.lublin.pl

itself and for the electrolyte (Figure 1a) and which may be modified by current stream and electrolyte properties. I-V measurement is possible in the two-electrode or three-electrode layout [3]. In the case of three-electrode measurement, a saturated calomel electrode (SCE) is usually used as the reference electrode. The reference electrode is introduced into the measuring circuit in order to enable the measurements with controlled potential on the indicated electrode in the relation to the potential of inner mass of the electrolyte (ISGND – Figure 1a).

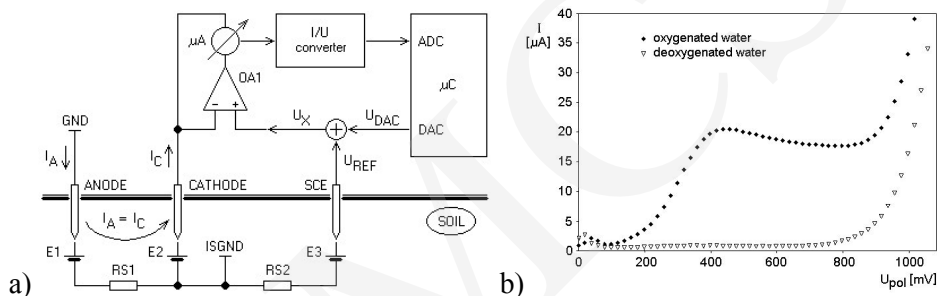

Fig. 1. The measuring circuit for determination of oxygen stream density in soil (a) and typical characteristics $I = f(U)$ for two different oxygenation levels in deionization water (b) [2]

2. Design assumptions – selection of micro-controller system

According to assumptions in the initial phase of recorder designing, the instrument should be designed as an autonomous unit with independent controlling microprocessor. The recorder should be designed in the manner enabling the measurements out of the laboratory. The recorder operation should be monitored by IBM PC computer. The exchange of control data and transmission of measurement data accumulated by the recorder should be carried out by means of serial transmission link. The assumptions associated with electrical/mechanical features of the measurement circuit have been specified in the following paragraphs:

- the recorder should be provided with nine independent measurement channels enabling their individual operation in the two-electrode or three-electrode layout with common electric ground for all anodes,
- the measurements of cathode current should be carried out with 12 bit resolution within $\pm 200 \mu\text{A}$,
- required range of polarizing voltages in the electrode system amounts $\pm 4000 \text{ mV}$, to be set with a spacing step of 1 mV (13 bit resolution),
- signal circuits, designed for the reference electrodes operation should be characterized by very high input resistance and should be resistant to industrial interference and furthermore:

- the measurement circuits should be operated in the groups incorporating three circuits each – with each group enabling the measurement in accordance with the characteristic settings for that group,
- in order to enable the work out of laboratory, the recorder should be supplied with the single voltage of 10.8V-13.2 V and its power input should be low,
- all measurement settings should be saved in EEPROM memory of the recorder,
- after its reprogramming, the recorder system should be suitable for other electrochemical measurements.

According to the assumptions included in the design, ADuC812 micro-controller supplied by Analog Devices [4] will be used for direct management of recorder operation. The micro-controller belongs to MCS51 [5] systems family. Except for standard features of MCS51 family, the ADuC812 system architecture has been supplemented with several auxiliary devices and associated services. The designed recorder described in the present paper will be directly integrated with a/m devices encompassing the following:

- two DAC 12 bit converters – ensuring voltage level regulation for the voltage polarizing the anode – cathode electrode groups,
- 8-channel, 12 bit ADC converter – for complete measurement operation,
- stable source of reference voltage – for DAC and ADC converters operation,
- EEPROM memory to enable the saving of recorder settings.

The last function is extremely convenient in the case of outdoor measurements. Owing to possibility of saving the recorder settings, recording is ready for measurement continuation immediately after switching on. It is very important in the case of integration with various PCs and execution of the measurements by the operating personnel not associated with the research project.

3. The electronic system of the recorder

The electronic section of the recorder has been designed as the typical structure for microprocessor systems, enabling the execution of measurement and data exchange with an external computer by means of serial transmission interface. The appearance of the recorder and its interior have been illustrated in photos 1a and 1b. Refer to Figure 2a for the block diagram of the recorder. Figure 2b represents the simplified diagram of a 13 bit bipolar polarizing voltage generator and Figure 2c the simplified diagram of single measurement circuit. The design of remaining measurement circuits is identical.

ADuC812 micro-controller generates the inter-electrode polarizing voltage anode – cathode, U_{DAC} , by means of a 13 bit DAC converter (Figure 2b). Then the U_{DAC} signal is transmitted to the measuring circuits by means of multiplexing

technique. The U_{ADC} signals to be converted in the ADC converter of the controller are also generated in the measuring circuits by means of multiplexing technique.

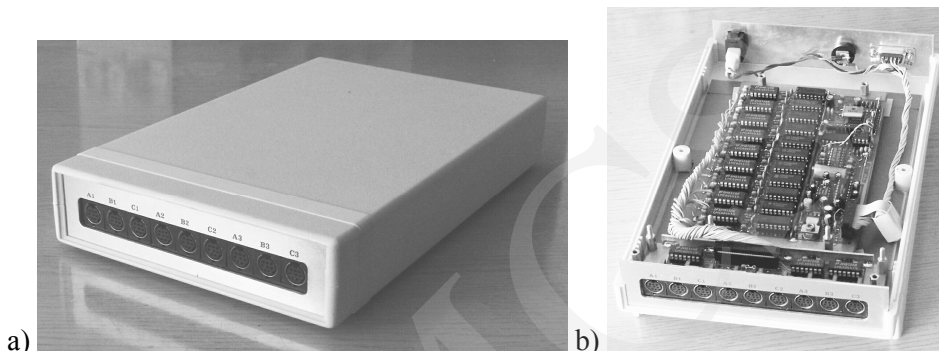

Photo 1. Recorder of curves $I = f(U)$: appearance of the recorder (a) and its interior (b)

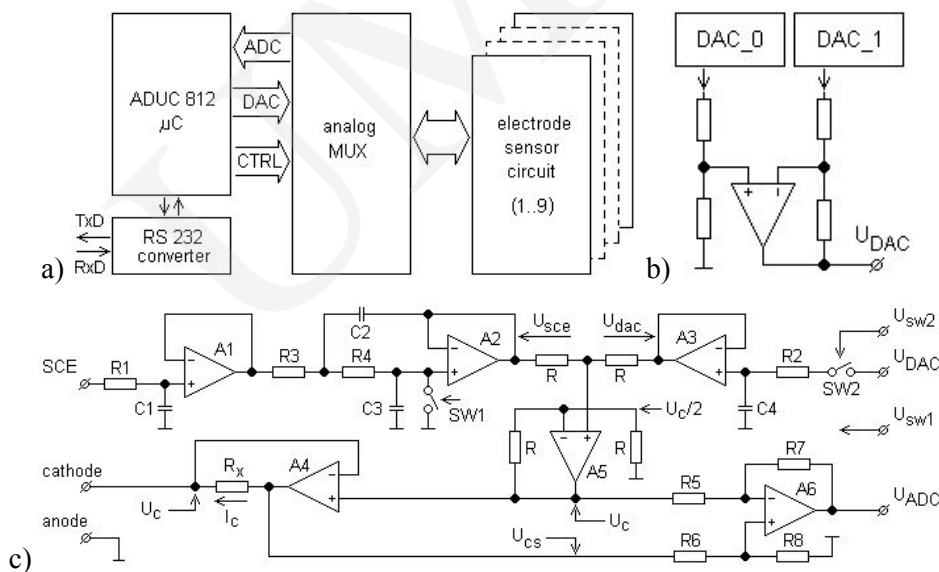

Fig. 2. Recorder of curves $I = f(U)$: block diagram of the recorder (a), polarizing voltage generator (b) and schematic diagram of single measurement circuit (c)

The schematic diagram of single measurement circuit has been illustrated in Figure 2c. The design solution of the channel corresponds to the system shown in Figure 1b. U_{SCE} signal supplied from the reference electrode U_{SCE} is subject to buffering by means of a high – resistance operational amplifier A1 and processing in order to eliminate industrial interference by means of active filter consisting A1 and A2 amplifiers. The output signal from the DAC converter is subject to sampling by means of R2, C4, SW2 elements and A3 amplifier to

form DC voltage signal U_{dac} . Both signals, U_{SCE} and U_{dac} are added in A5 amplifier resistor circuit and generate U_{C} sum signal. That voltage is repeated in the current source system, A4- R_{X} , on the electrodes system cathode and I_{C} current is generated. The recorder system operation in the two-electrode layout is forced by SW1 short-circuit condition.

The serial transmission link has been selected for data exchange between the recorder and control computer owing to UART port incorporated in ADuC812 micro-controller. The adaptation to electrical requirements of RS232C standard has been achieved by means of MAX232 [6] interface chip ensuring correct transmission with 19200Baudrate.

4. Programs supervising recorder operation

The recorder system described in the present paper has been designed as microprocessor based device. In order to enable its correct operation, the software set consisting of two elements has been prepared i.e. the internal program of ADuC812 micro-controller enabling the performance of the simplest controlling and checking functions in the recorder system and the exchange of information between the micro-controller and another computer. Another purpose of the internal program is the execution of measurement in accordance with the settings provided by the program supervising the operation of the recorder. That is another element of a/m software set enabling the measurements according to the settings specified by the user. The program should be installed in IBM PC computer program in active WIN 95/98/XP environment. The desk of recorder has the form of tabbed notebook. The elements of its graphical interface have been illustrated in Figure.3

The desk of recorder operation manager has been subdivided into several topic boxes to be selected by means of folders. The box "settings" enables complete definition of measurement settings for three groups of electrode systems. The remaining boxes to be selected by means of folders are information boxes enabling full monitoring of measuring process in the course of its duration.

The program operation is initiated by means of control pushbuttons set, situated in the upper part of the desk. The definition of the basic name and auxiliary names for data files and their locations on hard disk is possible by means of program functions to be selected by means of pushbuttons. Other control pushbuttons enable the reproduction of the settings used in preceding measurement and the commencement and stopping of the measurement.

The measuring session resulting in a group of files containing the measurement data is possible by means of the program. The measurement data files are generated in an automatic mode. The names of individual files are created by means of their basic name to be supplemented using the names of individual measuring groups and successive number of the measurement.

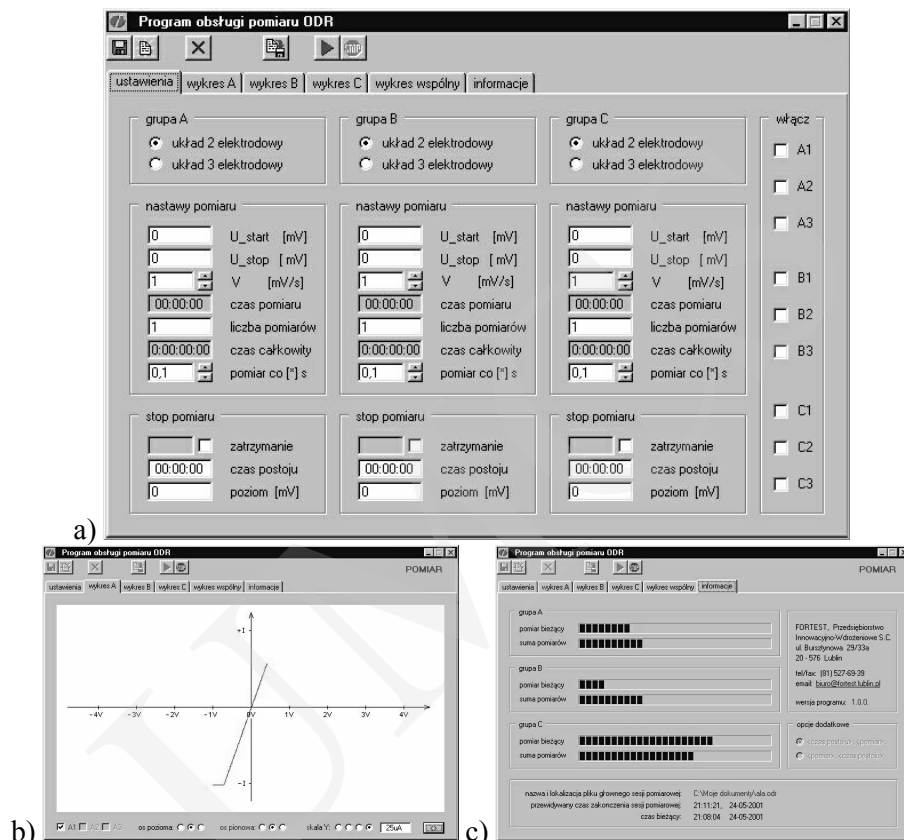

Fig. 3. Program supervising recorder operation – graphical interface: measurement settings page (a), measurement monitoring page (b), measurement progress informing page (c)

Any commencement of measuring session results in introduction of information associated with all measurement settings into the micro-controller EEPROM memory. In the case of repeated starting of the program supervising recorder operation, the settings are read and automatically located in the settings box of the program. That operation manner is equivalent to the operation of program being activated by means of initiating file.

5. Problems associated with ADuC812

As mentioned above, ADuC812 micro-controller has been selected among others owing to incorporated 12bit DAC and ADC converters as well as precision source of reference voltage. After construction of the recorder and execution of test measurements it appeared that the quality of the obtained results was imperfect. The curves obtained from the measurements $I = f(U)$ were characterized by significant noise level (Figure 4a). In respect of the

electrochemical analysis, the curve collapses (points B – Figure 4a) were the negative phenomenon which could be the symptom of polarographical wave generated by the potential depolariser [1]. More detailed analysis of the curve enabled the detection of its other repeating deformations indicated with the letter A. We can note that the points B may belong to A deformations, because they occur in the locations determined by A periodicity. After testing of the electronic circuits of the recorder, it has been found that ADC or DAC channels of the micro-controller are the potential source of errors.

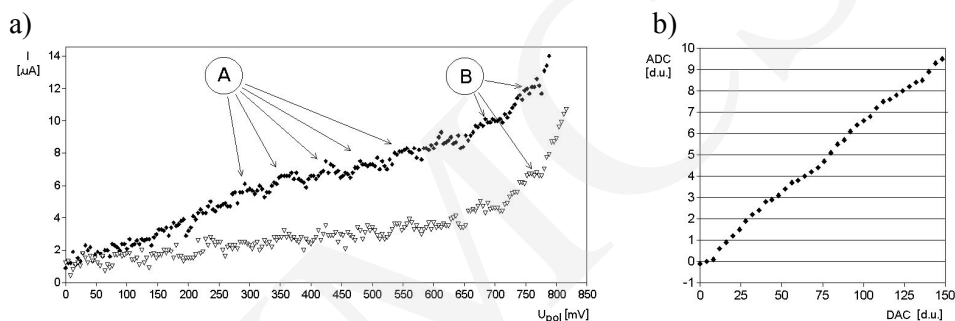

Fig. 4. Voltammetric curves with the errors resulting from measurement equipment (a) and diagram of DAC converter calibration curve fragment (b)

In order to perform ADC circuit testing, an analogue slowly variable voltage signal with linear amplitude increase vs. time, has been supplied to its input. After recording of a/m voltage, we have found the linear processing characteristic of ADC converter and that 12bit resolution could be attributed to the converter. Therefore ADC converter could be eliminated as the source of errors and could be used for testing of DAC converters.

In order to perform the testing of DAC channels of the micro-controller, the measurement has been performed in the two-electrode layout, with cathode and anode connected by means of a resistor. Refer to Figure 4b for a fragment of measurement result. After the correction consisting in deduction of experimental linear value from the curve, $Y = k \cdot X$, the curve assumed the shape shown in Figure 5a. The vertical axis is provided with the scale encompassing the successive binary values of ADC converter used for the measurement. The horizontal axis encompasses the successive steps of digital data entered into DAC converter. A periodical deviation of measured DAC converter signal from the linear function is visible in the diagram. The interval of repeating deformations is equal to 64 successive binary values entered into the DAC converter. The analysis of processing curve may suggest that the DAC converter consists of two 6 bit converters connected by means of summing node. The defect of output voltage generation may be caused by defective correction of resistor network in the younger part of two-element DAC converter.

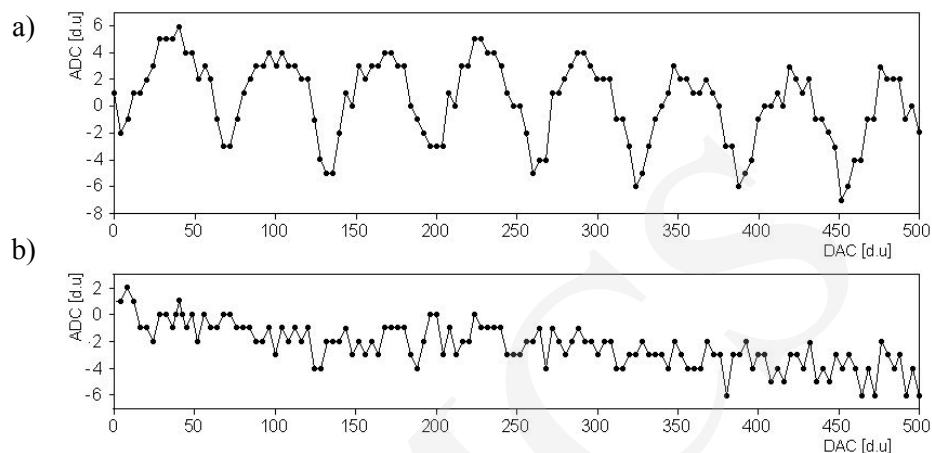

Fig. 5. DAC converter testing curves obtained from direct measurement without software correction (a) and after introduction of software correction (b). The vertical axis represent the output error generated by DAC converter

The attempt to correct the detected error by means of replacement of the micro-controller was ineffective. It may result from the fact that both micro-controllers originated from the same production lot [7]. Because the construction of a new recorder, on the basis of another micro-controller was impossible, the software correction method was applied to repair the defect of recorder. The repair consisted in the entry of data table with correction data set including 64 elements into ROM memory of the micro-controller. The correction data were obtained from the testing curve. DAC signal correction consists in entering of digital data modified by means of the correction data value, into the indicated DAC converter. As a result of such a simple action, the error of DAC converter has been reduced to the form illustrated in Figure 5b, resulting in significantly improved shape of voltammetric curves. The correction enabled the elimination of periodical deformations with relatively insignificant reduction of measurement interference.

Conclusions

The recorder has been designed as a specialized device to be used for determination of oxygen stream density in the course of soil oxygen micro-diffusion process. The independent measurement by means of nine electrode sets is possible by means of the recorder in the two-electrode or three-electrode layout. The selected electrical parameters are included in the following table:

current input	max 60mA (for 10.8V < U < 13.2V)
scope of settings for relative potential anode – cathode (in two-electrode layout)	+/- 4000 mV;
step of setting for relative potential	1mV;
accuracy of setting for relative potential (scatter between channels)	+/- 2mV;
LF noise level for relative potential	about 2mV;
crosstalk for relative voltage anode – cathode	under 1mV for difference of potentials between channels of 8000mV
maximum value of current measured in anode – cathode system	200 μ A
current determination system resolution	0.1 μ A
static input resistance of current amplifier for reference electrode	non-measurable – about 20T Ω m
dynamic input resistance of current amplifier for reference electrode	> 103M Ω m for f = 50Hz
low – pass filter design	active, 3 polar
input filter border frequency	3 Hz;
input filter attenuation dynamics	19dB/octave
measurement execution rate	10 measurements/second/channel

The recorder described in the present study met all assumptions established in the initial phase of the design. The errors associated with non-linear operation of DAC channels and detected in the course of the recorder testing, have been eliminated by means of software correction. Therefore the measuring capacity of the recorder has not been lost as a result of a/m defect. The defect of DAC converters detected in the course of testing has not been specified in the list of defects of ADuC812 micro-controller [8].

The project was sponsored by a private enterprise i.e. FORTEST, Przedsiębiorstwo Innowacyjno-Wdrożeniowe s.c. Lublin, Poland.

References

- [1] Cygański A., Metody elektroanalityczne; edition 2, WNT, Warszawa, (1995), in Polish.
- [2] Malicki M.A., Bieganowski A., Kotliński J., „Zestaw do wyznaczania charakterystyk napięciowo-prądowych układu elektrody – gleba w zastosowaniu do oceny natlenienia gleby”; IX Szkoła „Fizyka z Elementami Agrofizyki”, Lublin, (1997) 41, in Polish.
- [3] Malicki M., Measurements of redox potential and oxygen diffusion rate (ODR) in the soils; Zeszyty Problemowe Postępów Nauk Rolniczych, 338 (1990) 115, in Polish.
- [4] Product specification: „MicroConverter™, Multichannel 12-Bit ADC with Embedded FLASH MCU ADuC812”; Analog Devices, (1999).
- [5] INTEL literature: „8-bit Embedded Controller Handbook”, Intel Corporation, (1990).
- [6] Product specification: „+5V-Powered Multichannel RS-232 Drivers/Receivers”; Maxim Integrated Products, (1997).
- [7] Chip overprint: ADUC812BS, 9950, F113332.1; chip kernel: ‘ADI V201’.
- [8] ADuC812 Errata file: „er812e0.pdf”; Analog Devices, (1999).